

DS-K3B802BX Swing Barrier

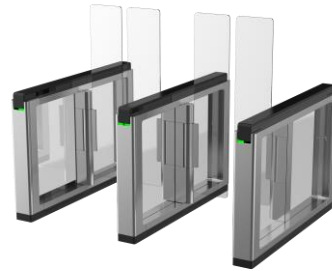

The swing barrier with two barriers and 24 pairs of IR lights is designed to detect unauthorized entrance or exit. By adopting the swing barrier integrated with the access control system, person should authenticate to pass through the lane via swiping IC or ID card, scanning QR code, etc. It is widely used in high-end offices, government buildings, hotels, airports, etc.

- Built-in card reader and access controller.
- The door wings will be locked or stop working when people are nipped.
- Self-detection, Self-diagnostics, and automatic alarm.
- Fire alarm passing: When the fire alarm is triggered, the barrier will be open automatically for emergency evacuation.
- Audible and visual alarm will be triggered when detecting intrusion, tailgating, reverse passing, climbing over barrier, and overstay.
- The barrier's material is high-strength tampered glass, sticked with film, which will not cause injury when the glass is broken.
- TCP/IP network communication: The communication data is specially encrypted to relieve the concern of privacy leak.

▪ Specification

System	
Motor	Servo motor
MCBF	> 6 million times
Interface	
Network interface	1
Lock control	2
Alarm input	2
Alarm output	2
Capacity	
Fingerprint capacity	5,000 (optional)
Card capacity	1,000,000
Event capacity	1,000,000
General	
Throughput	30 to 60 persons per minute The actual throughput is affected by the person passing rate and passing method
IR light detectors	24 pairs
Distance between Barrier and Ground	1.2 m, 1.4 m, 1.6 m, 1.8 m
Lane width	650 mm to 900 mm(25.6" to 35.43")
Barrier material	Tempered glass (8mm)
Pedestal material	SUS304 stainless steel with the thickness of 2 mm (0.08")
Built-in access controller	Yes
Power supply	100 to 240 VAC; 50 to 60 Hz
Working temperature	-10 °C to 55 °C (14 °F to 131 °F)
Working humidity	0% to 95% (no condensing)
Power consumption	60W (stand by)
Dimensions	With packaging: 1670 mm × 490 mm × 1180 mm (65.8" × 19.3" × 46.5") Without packaging: 1500 mm × (160+64.5)mm × 1010 mm (59.1" × 8.84" × 39.8")
Weight	Not include door wings (Net) Left: 99.34 kg (219.00 lbs) Middle: 108.8 kg (239.86 lbs) Right: 102.8 kg (226.64 lbs) (Rough) Left: 147.8 kg (325.84 lbs) Middle: 157.26 kg (346.70 lbs) Right: 151.26 kg (333.47lbs)
Application environment	Indoor
Approval	CE/CB/RoHS/REACH/WEEE
Configuration	
Lane width	650, 750, 900
Pedestal length	1500 mm
Module selection	NO
Pedestal width	225 mm
Wall distance	50 mm
Base	YES
Barrier material	Tempered glass

Authentication mode	Card, Face, Fingerprint, QR code
Card type	EM, M1, Desfire, Felica
Recommended width	650
Base model	DS-K3B802X-BASE
Product type	Swing barrier
Remote controller type	433Mhz, 868Mhz
Door wing height	1.2m, 1.4m, 1.6m, 1.8m

▪ Maintenance

The main element of the turnstile is stainless steel, which is rustless (antioxidant) and corrosion resistant (The anti corrosion ability in the medium of acid, alkali, and salt). In order to keep the stainless steel from being oxidized or corroded, you should clean and care the turnstile surface periodically .

The instructions and tips for maintaining the turnstile are as follows:

- Select different stainless steel types according to the variety of the environments. You can select 304 stainless steel for common circumstances and 316 stainless steel for the scenarios of seashores and chemical plants.
- Keep the device surface clean and dry.
- Use non-woven cloth and ethyl alcohol to clean the dirt on the device surface.
- Use sourcing pad (do not use mesh cleaning ball) to clean the rust on the device surface by following the wire drawing on the stainless steel. And then use non-woven cloth and stainless steel cleaner to wipe the device surface.
- Clean and maintain the device by using non-woven cloth and stainless steel cleaner periodically. It is suggest to clean the device every month in common circumstances and every week for severe environments (seaside and chemical plants for instance).

▪ Dimension

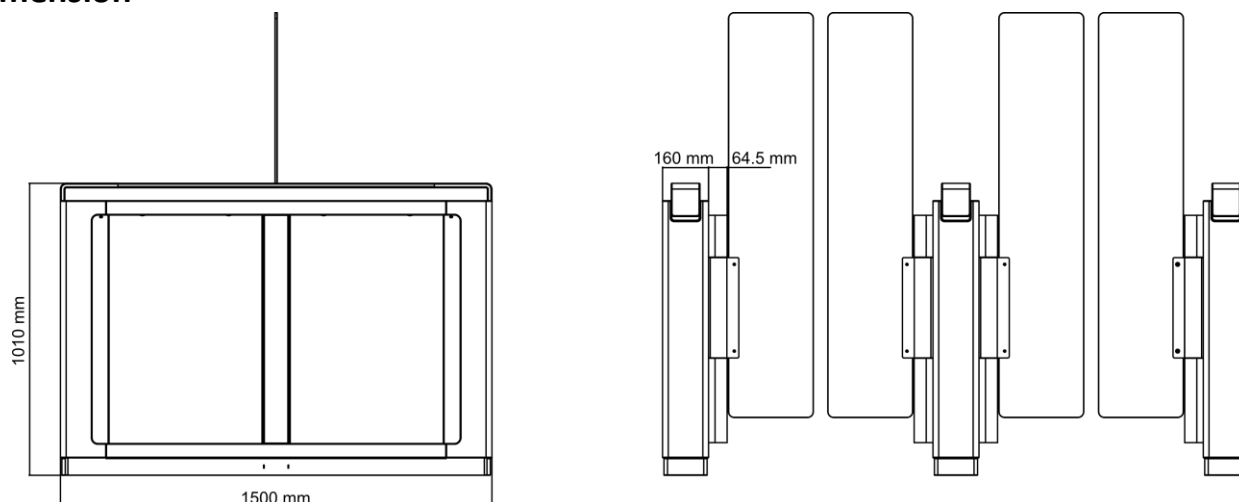

▪ **Accessory**

▪ **Included**

DS-K7CR01



▪ **Optional**

DS-K7R01-433 Wireless Kefob 433MHz	DS-K7R01-868 Wireless Kefob 868MHz	DS-K3B802X-BASE Fixed Base
		

Headquarters

No.555 Qianmo Road, Binjiang District,
Hangzhou 310051, China
T +86-571-8807-5998
www.hikvision.com



Follow us on social media to get the latest product and solution information.

